

1	2	3	4	5
A				A
B				B
C				C
D				D
1	2	3	4	5

Sheet: High side bias supply  
 B1 – high side +17.5V/-5V bias supply

File: ISO5852SDW-B1.sch

Sheet: Low side bias supply  
 B2 – low side +17.5V/-5V bias supply

File: ISO5852SDW-B2.sch

Sheet: Connector, protection, fault  
 B3 – connectors, UVLO/OVLO protection, fault and reset logic, overlapping option setting

File: ISO5852SDW-B3.sch

Sheet: High side driver wt booster desaturation  
 B4 – high side driver with booster and desaturation protection

File: ISO5852SDW-B4.sch

Sheet: Low side driver wt booster desaturation  
 B5 – low side driver with booster and desaturation protection

File: ISO5852SDW-B5.sch

Sheet: Input bus voltage sensing  
 B6 – input bus voltage sensing isolated amplifier

File: ISO5852SDW-B6.sch

ISO5852SDW Driving and Protection SiC and IGBT Power Modules  
 Selon conception Texas Instruments (SLLU298)  
 Dessiné par Bruno Tremblay, Ing.

**Volt-Fast UQAR**

Sheet: /  
 File: VF\_ISO5852SDW\_V1.sch

**Title: Racine hiérarchique du schéma**

Size: A Date: 2021-01-27  
 KiCad E.D.A. kicad (5.1.9)-1

Rev: 0  
 Id: 1/7

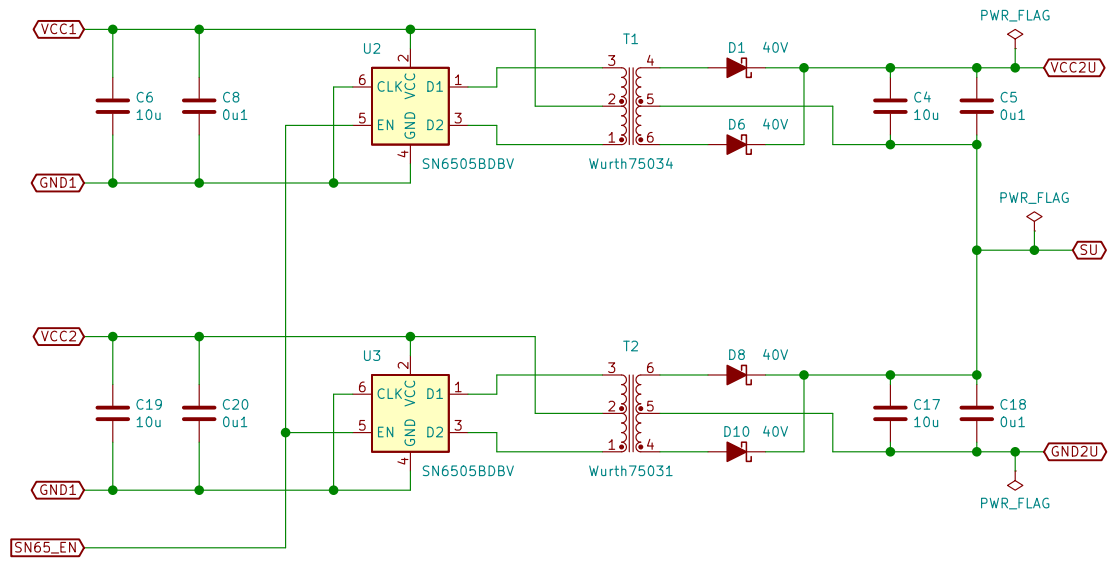

ISO5852SDW Driving and Protection SiC and IGBT Power Modules	
Selon conception Texas Instruments (SLLU298)	
Dessiné par Bruno Tremblay, Ing.	
<b>Volt-Fast UQAR</b>	
Sheet: /High side bias supply/	
File: ISO5852SDW-B1.sch	
<b>Title: B1 - high side +17.5V/-5V bias supply</b>	
Size: A	Date: 2021-01-27
KiCad E.D.A. kicad (5.1.9)-1	Rev: 0
	Id: 2/7

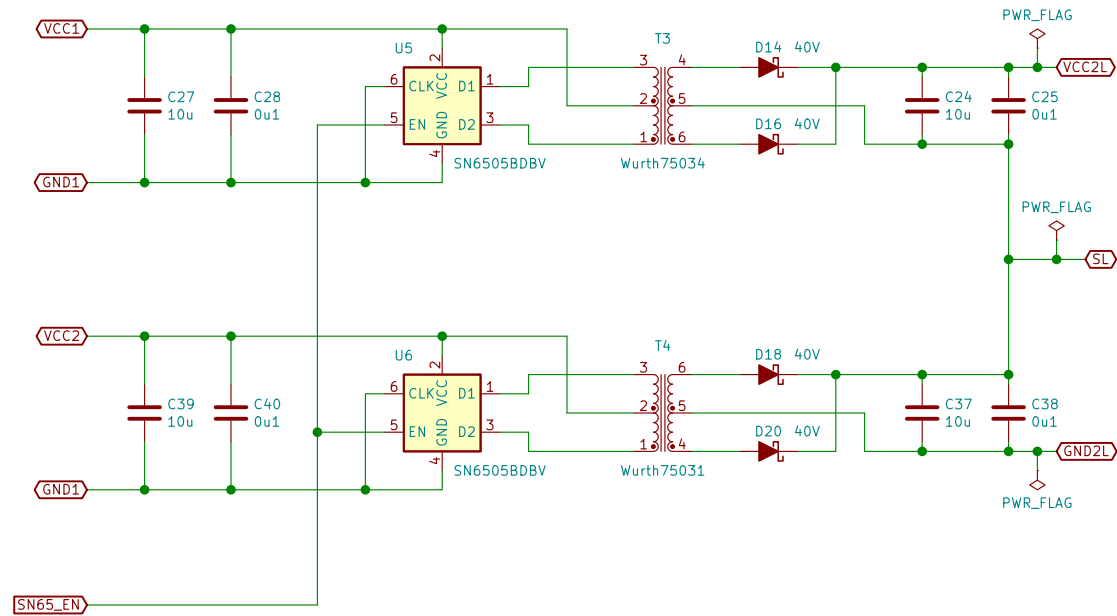

ISO5852SDW Driving and Protection SiC and IGBT Power Modules  
 Selon conception Texas Instruments (SLLU298)  
 Dessiné par Bruno Tremblay, Ing.

**Volt-Fast UQAR**  
 Sheet: /Low side bias supply/  
 File: ISO5852SDW-B2.sch

**Title: B2 - low side +17.5V/-5V bias supply**

Size: A	Date: 2021-01-27	Rev: 0
KiCad E.D.A. kicad (5.1.9)-1		Id: 3/7

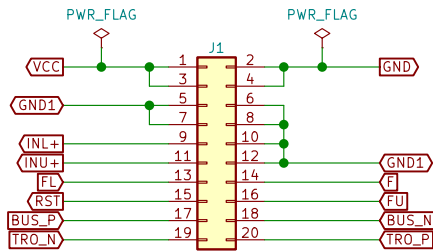

Connecteur des signaux de commande

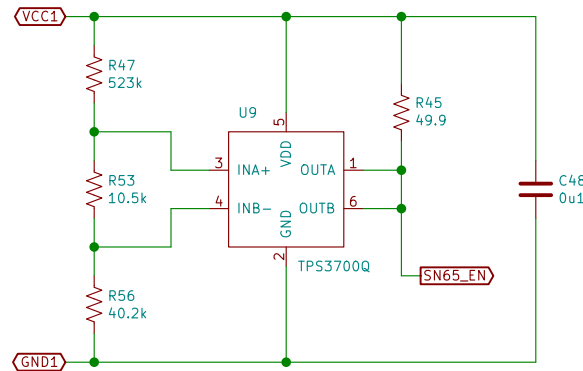

Comparateur Over/under voltage

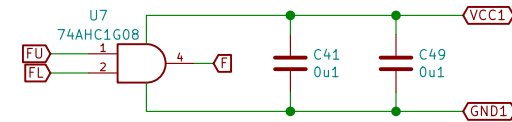

Combinaison des fautes

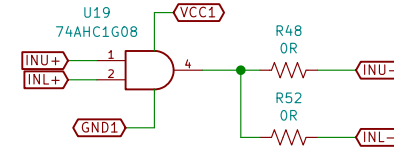

Détection de chevauchement

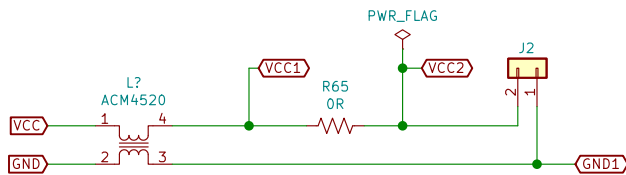

Filtre d'alimentation et alimentation auxiliaire

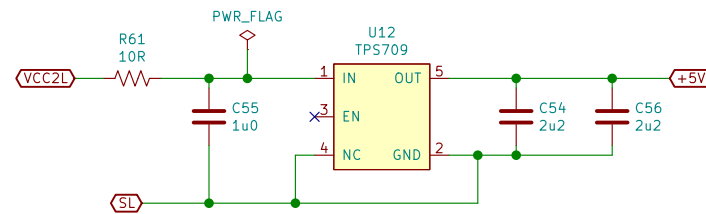

Régulateur de tension

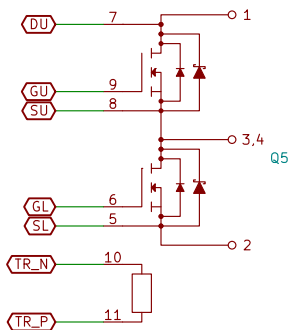

Module de transistors SiC

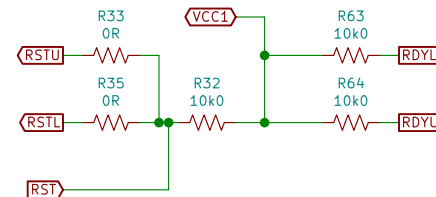

ISO5852SDW Driving and Protection SiC and IGBT Power Modules  
 Selon conception Texas Instruments (SLLU298)  
 Dessiné par Bruno Tremblay, Ing.

**Volt-Fast UQAR**

Sheet: /Connector, protection, fault/  
 File: ISO5852SDW-B3.sch

**Title: B3 - connectors, UVLO/OVLO protection, fault and reset logic**

Size: A Date: 2021-01-27  
 KiCad E.D.A. kicad (5.1.9)-1

Rev: 0  
 Id: 4/7

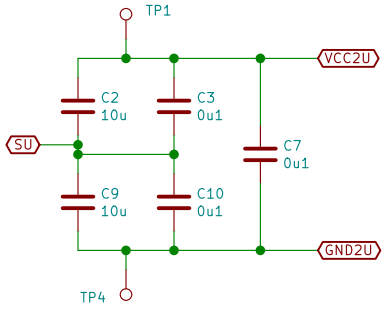
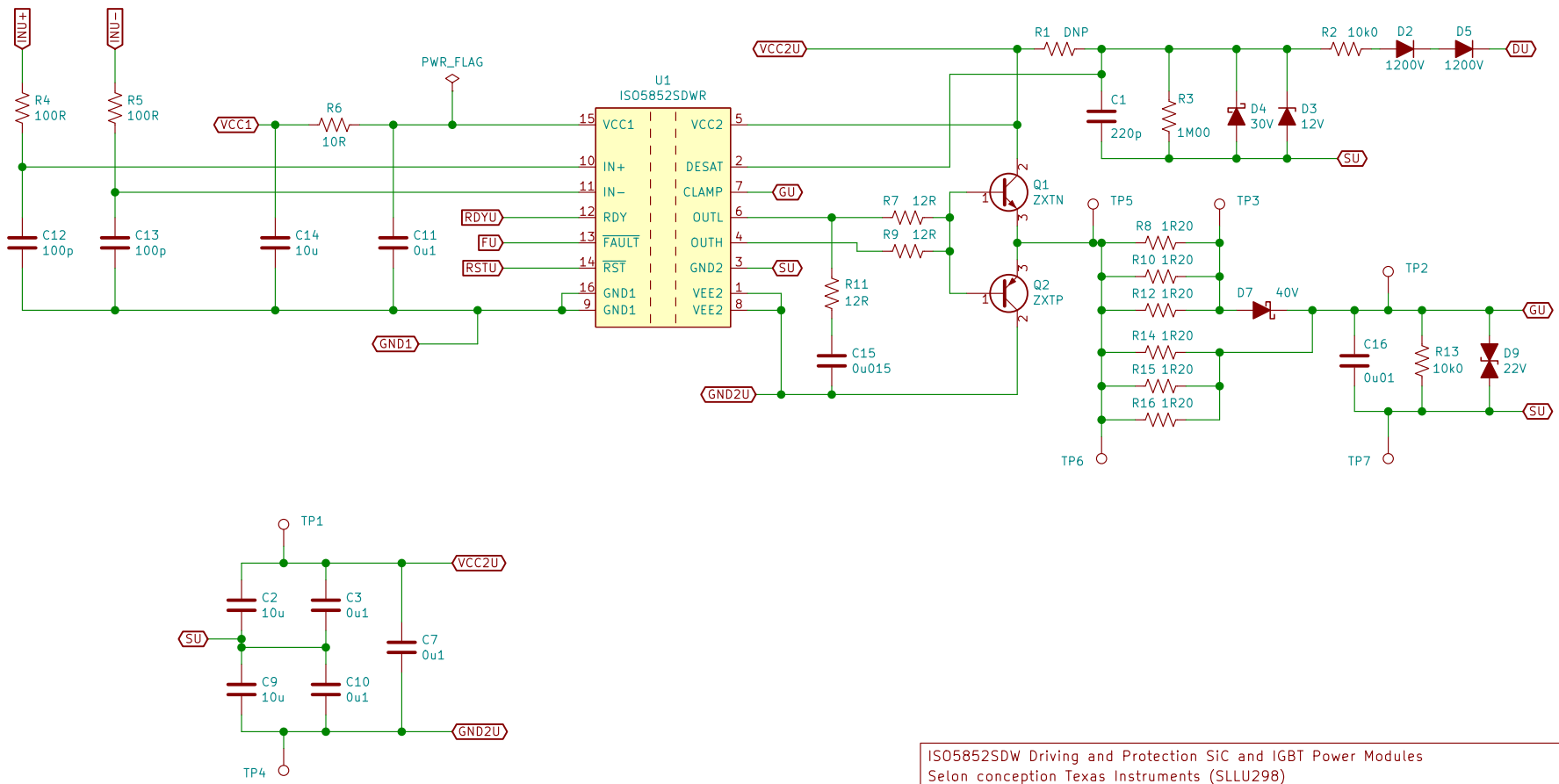

ISO5852SDW Driving and Protection SiC and IGBT Power Modules  
 Selon conception Texas Instruments (SLLU298)  
 Dessiné par Bruno Tremblay, Ing.

**Volt-Fast UQAR**  
 Sheet: /High side driver wt booster desaturation/  
 File: ISO5852SDW-B4.sch

**Title: B4 - high side driver with booster and desaturation**

Size: A	Date: 2021-01-27	Rev: 0
KiCad E.D.A. kicad (5.1.9)-1		Id: 5/7

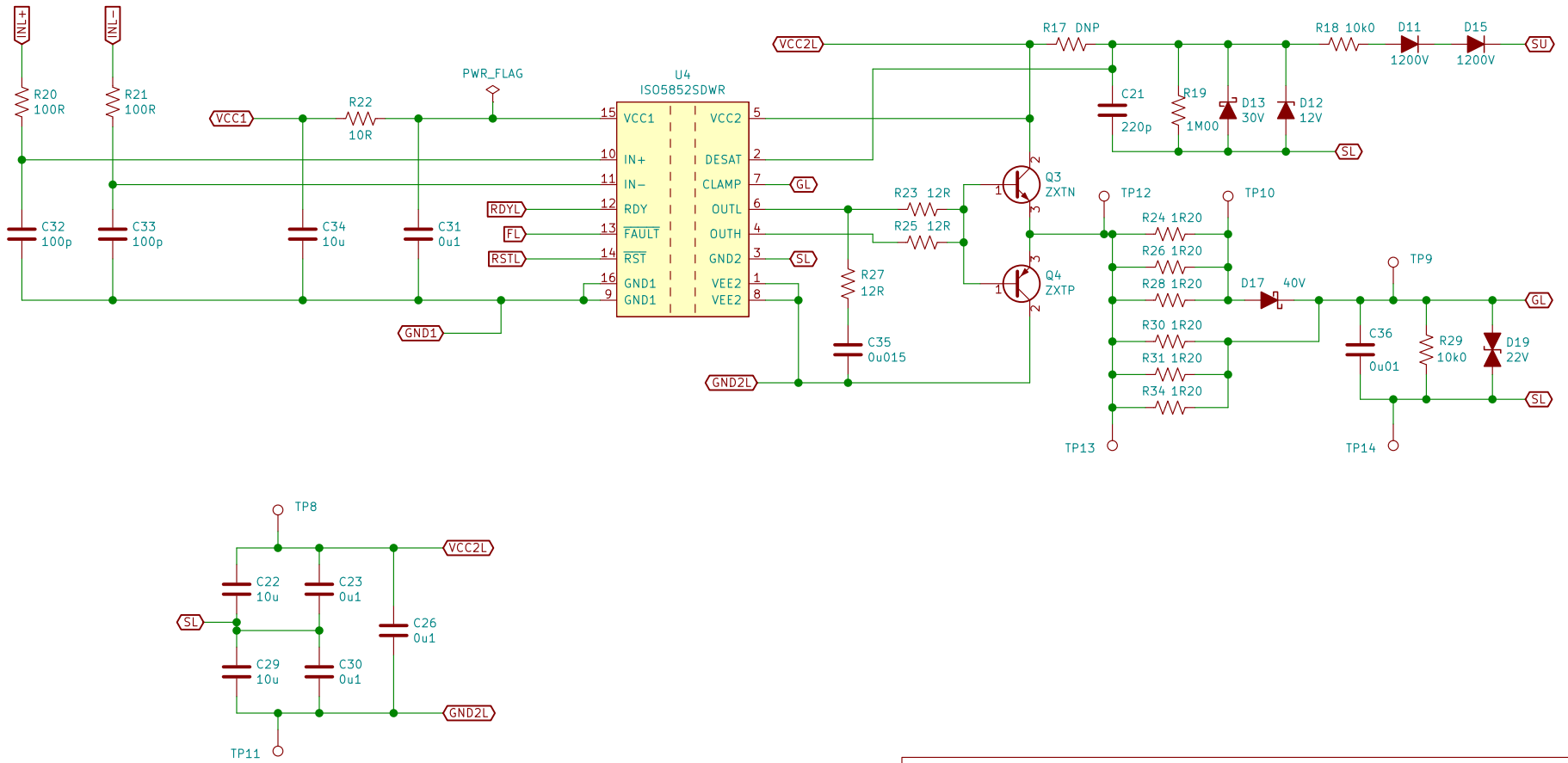

ISO5852SDW Driving and Protection SiC and IGBT Power Modules  
 Selon conception Texas Instruments (SLLU298)  
 Dessiné par Bruno Tremblay, Ing.

**Volt-Fast UQAR**  
 Sheet: /Low side driver wt booster desaturation/  
 File: ISO5852SDW-B5.sch

**Title: B5 - low side driver with booster and desaturation**

Size: A	Date: 2021-01-27	Rev: 0
KiCad E.D.A. kicad (5.1.9)-1		Id: 6/7

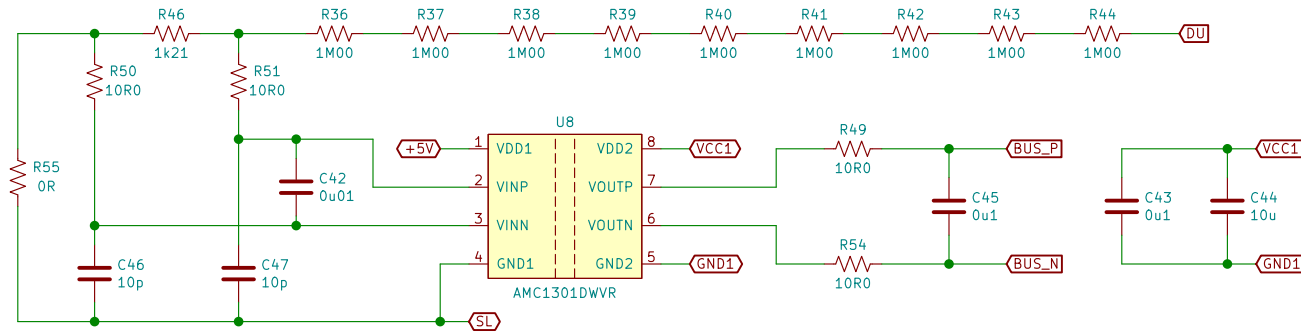

Mesure de la haute tension et amplificateur d'isolation

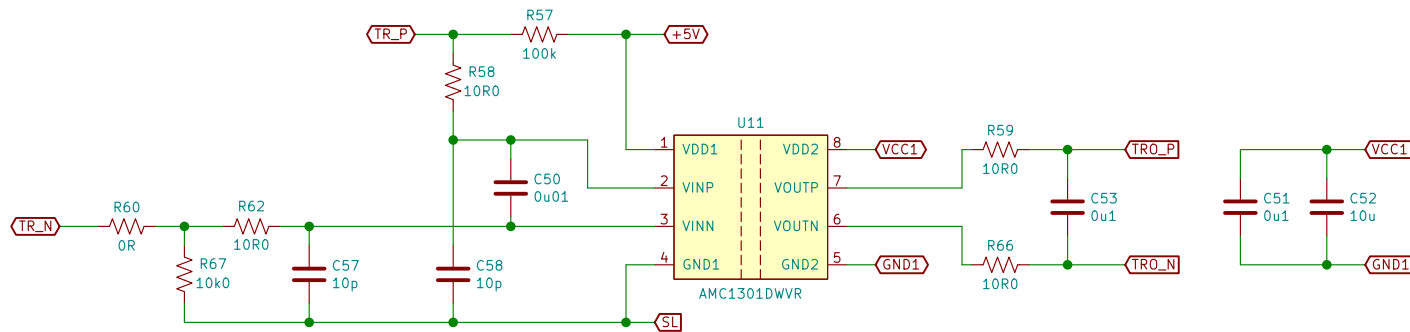

Mesure de température du module et amplificateur d'isolation

ISO5852SDW Driving and Protection SiC and IGBT Power Modules  
 Selon conception Texas Instruments (SLLU298)  
 Dessiné par Bruno Tremblay, Ing.

**Volt-Fast UQAR**

Sheet: /Input bus voltage sensing/  
 File: ISO5852SDW-B6.sch

**Title: B6 - Input bus voltage sensing isolated amplifier**

Size: A Date: 2021-01-27  
 KiCad E.D.A. kicad (5.1.9)-1

Rev: 0  
 Id: 7/7